



Consulting, help, relaxation

**INTERNATIONAL JOURNAL OF ENGINEERING SCIENCES
&
MANAGEMENT**

**MODELING AND SIMULATION OF SIX-PHASE PERMANENT MAGNET
SYNCHRONOUS MOTOR DRIVE**

Preeti Mishra* and Satya Prakash Dubey

Electrical Engineering Department,

Rungta College of Engineering & Technology, Kohka-Kurud Road, Bhilai-490024 (C.G.) India

ABSTRACT

The use of six-phase permanent magnet synchronous motor for industrial drives presents several advantages over the conventional three phase drive such as improved reliability, magnetic flux harmonic reduction, torque pulsations minimization and reduction on the power ratings for the static converter. This paper investigates a six- phase permanent magnet synchronous motor supplied by two independent voltage source three-phase inverters with PWM generators. This paper presents the modeling and simulation of six phase permanent magnet synchronous motor using MATLAB/SIMULINK software. The proposed model is simulated under various loading conditions and the results found to be satisfactory.

Key words: Six-phase permanent magnet synchronous motor, Voltage source three phase inverter, Proportional integral controller, PWM generator, MATLAB software

INTRODUCTION

Multiphase AC motors have been extensively studied in recent years [1], [2]. Multiphase AC motors have some advantages such as reduce the single static switches current stress, smooth the electromagnetic torque pulsation, increase the efficiency, decrease the total losses, reduce magnetic flux harmonic and improve reliability [3], [4]. Three-phase PMSM machines are today a standard for industrial electrical drives. Cost, reliability, robustness and maintenance free operation are among the reasons these machines are replacing dc drive systems.

The main application areas of multiphase PMSM drives are ship propulsion, traction (including electric and hybrid electric vehicles) and the concept of more-electric aircraft. Other suitable applications are locomotive traction [1], aerospace and high power applications [2]. The six-phase motor has some advantages against the other multiphase motors: the six phase motor, fed by frequency converter, has no the third of aliquot to three magnetic flux harmonics.

The development of power electronics and signal processing systems has eliminated one of the greatest disadvantage of such ac systems, that is the issue of control. With modern techniques of field oriented vector control, the task of variable speed control of PMSM is no longer a disadvantage. A growing interest in multiphase machines (i.e. machines with more than three -phase) is caused by the fact that these machines can provide notable improvements in various aspects of performance when compared with the use of their conventional three-phase counterparts. Moreover, the six-phase machines can be enhancing the system performance and output power via the multiphase inverter drives system technologies [5], [6].

The researches about six-phase PMSM can be found [7], [8]. In [7] the sensorless technology of six-phase PMSM was proposed to estimate the rotor angle and phase current. In [8] a finite-element method-based analysis of output power capability improvement in a six-phase flux-weakened PMSM with a third harmonic current injection has been proposed. If one of the three -phase winding or the respective inverter is broken, the power rating of the PMSM is reduced to half and still can be operated safely using the remaining three-phase winding, so that the operating safety of the system can be increased. For these

***Corresponding Author**

Email: preeti.mishra24@yahoo.com,
spd1020@yahoo.com

reasons, the fault tolerant controls of a six-phase PMSM, where two three-phase winding are spatially shifted 30 electrical degrees to reduce the torque ripple.

The most common multiphase machine structure is a dual three-phase machine (also known as an asymmetrical six-phase machine, a split-phase machine or a double star machine). This machine has two sets of star-connected three phase stator windings spatially shifted by 30 electrical degrees with isolated neutral points. Dual three phase machines have been successfully applied to full redundant ship propulsion drives for several years and now also used in wind power systems and other high-power industrial applications.

Multiphase PMSM drives are currently invariably supplied from two-level multiphase voltage source inverters. As the number of phases of the inverter increases, the available number of inverter output voltage space vectors changes according to the law 2^n . Hence five-phase VSI offers 32 voltage space vectors, while a nine-phase VSI (supplying a symmetrical nine-phase machine with single neutral point) has 512 output voltage space vectors. This means that, as the number of phases increases, the problem of devising an adequate space vector PWM scheme becomes more and more involved. On the other hand, carrier-based PWM for three-phase VSIs is easily extendable to multiphase VSIs.

Various supply methods have been suggested in which a common approach is a special six-phase [13] or a direct torque control. In addition, a predictive current control has been proposed [14]. Regardless of how impressive their performance might be, these methods are not standard off-the-shelf technology, which makes it more difficult to use them in industrial applications. In this respect, two independent three-phase inverters could be a preferred alternative. This paper aims to present performance analysis of a six-phase permanent magnet synchronous motor model consists of two three phase inverter with PWM generators under different operating conditions with a conventional vector control principle. In this paper mathematical modeling of six-phase PMSM has been done which is fed by two three phase IGBT based inverters whose gating signals are controlled by PWM generators. The results are taken under different loading conditions and under no load conditions; such as at rated speed during no load, at rated speed with any load and with variation in speed at rated loaded condition and the results are found to be satisfactory.

MACHINE MODEL

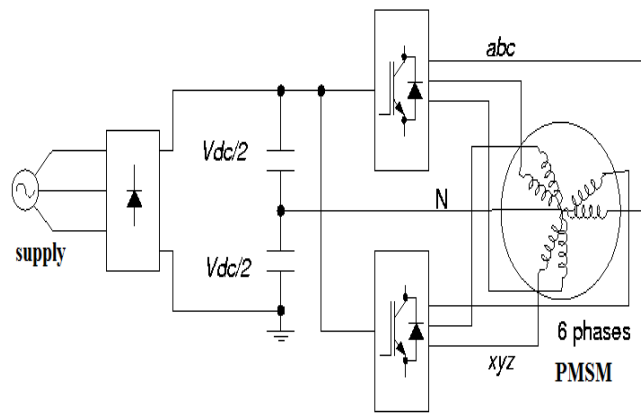

Fig. 1: Six-Phase machine drive system

Fig. 1 shows a six-phase machine drive system which have a permanent magnet synchronous motor whose stator winding is spatially shifted by 30 electrical degrees with isolated neutral points which is fed by two three phase voltage source inverter, In this study, a six-phase PMSM with two three phase winding is adopted where *abc* winding is spatially 30 electrical degrees phase led to *xyz* winding. The phase voltage and flux linkage equations in the stationary reference frames for *abc* winding and *xyz* winding of six phase PMSM are shown:

$$V_{abc} = \check{R}_s i_{abc} + \frac{d}{dt}(\phi_{abc}) \tag{1}$$

$$\phi_{abc} = \check{L}_{11} i_{abc} + \check{L}_{12} i_{xyz} + \phi'_{mabc} \tag{2}$$

$$V_{xyz} = \check{R}_s i_{xyz} + \frac{d}{dt}(\phi_{xyz}) \tag{3}$$

$$\phi_{xyz} = \check{L}_{22} i_{xyz} + \check{L}_{21} i_{abc} + \phi'_{mxyz} \tag{4}$$

where $\check{R}_s = [R_s \ R_s \ R_s]^T$ is the stator resistance vector; $V_{abc} = [V_a \ V_b \ V_c]^T$ is the phase voltage vector of *abc* winding; $i_{abc} = [i_a \ i_b \ i_c]^T$ is the current vector of *abc* winding; $V_{xyz} = [V_x \ V_y \ V_z]^T$ is the phase voltage vector of *xyz* winding; $i_{xyz} = [i_x \ i_y \ i_z]^T$ is the current vector of *xyz* winding; $\phi_{abc} = [\phi_a \ \phi_b \ \phi_c]^T$ is the stator flux linkage of *abc* winding; $\phi_{xyz} = [\phi_x \ \phi_y \ \phi_z]^T$ is the stator flux linkage of *xyz* winding; \check{L}_{11} is the stator inductance vector of *abc* winding; \check{L}_{22} is the stator

inductance vector of xyz winding; \tilde{L}_{12} and \tilde{L}_{21} are the mutual inductance vectors Φ'_{mabc} is the permanent magnet flux linkage vector of abc winding; Φ'_{mxyz} is the permanent magnet flux linkage vector of xyz winding.

To control the six-phase PMSM, following transformation matrixes have been used to transfer the above equations into synchronous rotating reference frame:

$$T_{dq1} = \frac{2}{3} \begin{bmatrix} \cos\theta_e & \cos(\theta_e - 120^\circ) & \cos(\theta_e + 120^\circ) \\ \sin\theta_e & \sin(\theta_e - 120^\circ) & \sin(\theta_e + 120^\circ) \\ \frac{1}{2} & \frac{1}{2} & \frac{1}{2} \end{bmatrix} \quad (5)$$

$$T_{dq2} = \frac{2}{3} \begin{bmatrix} \cos(\theta_e - 30^\circ) & \cos(\theta_e - 150^\circ) & \cos(\theta_e + 90^\circ) \\ \sin(\theta_e - 30^\circ) & \sin(\theta_e - 150^\circ) & \sin(\theta_e + 90^\circ) \\ \frac{1}{2} & \frac{1}{2} & \frac{1}{2} \end{bmatrix} \quad (6)$$

where; T_{dq1} is the transformation matrix for abc winding; T_{dq2} is the transformation matrix for xyz winding; θ_e is the rotor flux angle. However, the machine model of a six phase PMSM can be described in synchronous rotating reference frame as follows [14], [15]:

$$v_{q1} = R_s i_{q1} + L_{dq11} \frac{d}{dt} i_{q1} + \omega_e (L_{d11} i_{d1} + \Phi'_m) \quad (7)$$

$$v_{d1} = R_s i_{d1} + L_{d11} \frac{d}{dt} i_{d1} - \omega_e L_{q11} i_{q1} \quad (8)$$

$$v_{q2} = R_s i_{q2} + L_{dq22} \frac{d}{dt} i_{q2} + \omega_e (L_{d22} i_{d2} + \Phi'_m) \quad (9)$$

$$v_{d2} = R_s i_{d2} + L_{d22} \frac{d}{dt} i_{d2} - \omega_e L_{q22} i_{q2} \quad (10)$$

$$\omega_e = \frac{p}{2} \omega_r \quad (11)$$

where v_{q1} and v_{d1} are the d-q axis voltages of abc winding; v_{q2} and v_{d2} are the d-q axis voltages of xyz winding; i_{d1} and i_{q1} are the d-q axis currents of abc windings; i_{d2} and i_{q2} are the d-q axis currents of xyz windings; L_{q11} and L_{d11} are the d-q inductance of abc winding; L_{d22} and L_{q22} are the d-q inductance of xyz winding; ω_r is the rotor angular velocity; ω_e is the electrical angular velocity; Φ'_m is the permanent magnet flux linkage; p is the number of pole pairs of six-phase PMSM. Developed torque can be represented by following equation:

$$T_e = \frac{3}{2} \frac{p}{2} \left((L_{d11} i_{d1} + \Phi'_m) i_{q1} + (L_{d11} - L_{q11}) i_{d1} i_{q1} \right) + (L_{d22} i_{d2} + \Phi'_m) (L_{d22} - L_{q22}) i_{d2} i_{q2} \quad (12)$$

Six-phase PMSM works on the basic principle based on field oriented control in which both i_{d1} and i_{d2} in (12) are set to be zero then d-axis flux linkages $[(L_{d11} i_{d1} + \Phi'_m) i_{q1} + (L_{d11} - L_{q11}) i_{d1} i_{q1}]$ are fixed due to Φ'_m is a constant for a six-phase PMSM.

Mechanical dynamic equation of six phase PMSM is:

$$T_e = J \frac{d\omega_r}{dt} + B\omega_r + T_L \quad (13)$$

where J is inertia of six-phase PMSM; B is the damping coefficient; T_L is the load torque.

BLOCK DIAGRAM OF SIX-PHASE PMSM DRIVE

The drive system considered in Fig.2 consists of PI speed controller and limiter, the reference current generator, current regulator, six-phase PMSM and two IGBT based voltage source inverter. All these components are modeled and integrated for simulation in real time conditions. Fig 2 shows the basic building block diagram of six-phase PMSM motor drive system. The control system consists of an outer speed feedback loop and an inner current feedback loop. There are two reference current generating unit from which three current signal are given out that means a total of six current signal are given from two current generator unit. Two of the three-phase current signals along with the speed signal are sensed and are used as feedback signals. The speed (ω_r) of the motor is compared to the reference speed (ω_r^*) and the error (ω_{re}) is processed in the speed controller. A limit is kept on the output of the speed controller depending upon maximum permissible torque developed by the motor. The output of the speed controller (T) after limiting is considered as the reference torque (T^*). From PI controller the signal is sent to two dq-abc block (also called as park's transformation block) for vector control. This block performs the conversion of the dq current component in the rotor reference frame into abc phase variables. In this control method the direct axis current made to be zero. From two dq-abc block (reference current generator) six current signals are compared with the six current signals of motor and the error signals are sent to two three-phase inverter

which is a voltage source inverter, controlled by PWM.

The reference generator generates a reference signal for each of the phase. To generate the reference signals, it requires the position of the rotor which is supplied by the Theta generation block (Integrator). The feedback current signals and the reference signals are fed in to the current controller. The error between the actual currents and the reference currents are used as modulating signals. The output from the current controller is used for gating the switches of the inverter. The above figure shows the six-phase PMSM drive model consisting the simulink model of six-phase permanent magnet synchronous motor which can be built by using mathematical equations, two three-phase IGBT based voltage source inverter whose gating signals are provided by PWM generators, park's transformation block to convert abc coordinates of inverter to dq coordinates of motor, PI controller, inverse park's transformation block.

Control of six-phase PMSM motors is performed using field oriented control for the operation of synchronous motor as a dc motor. An inverter fed the stator windings of motor that generates a variable frequency variable voltage. As an alternative of controlling the inverter frequency independently, the phase and frequency of the output wave are controlled using a position sensor. Field oriented control was invented in the beginning of 1970s and it demonstrates that an induction motor or synchronous motor could be controlled like a separately excited dc motor by the orientation of the stator mmf or current vector in relation to the rotor flux to achieve a desired objective. In order for the motor to behave like DC motor, the control desires knowledge of the instantaneous rotor flux position or rotor position of permanent magnet motor. Knowing the position, the three phase currents can be calculated. The vector control separates the torque component of current and flux channels in the motor through excitation in stator. The vector control of the permanent magnet synchronous motor is derived from its dynamic model.

The vector controller block computes the six reference motor line currents and generates the error signal which is given to corresponding PWM generator and this signals act as gating signals for inverter. Then the signals are sent to Inverse Park's transformation block (also called as abc-dq transformation block) and then send to six-phase motor.

SIMUALTION RESULTS

Simulation of Six-phase PMSM is carried out using MATLAB/SIMULINK. The machine parameters are presented in TABLE I.

Table I: Motor parameter

Rated power	2Kw
Rated current	11.4 A
Rated torque	6.5 Nm
DC link voltage	800V
Rated speed	35.6 radians/sec
Pole pair	4
Stator resistance R_s	0.64 Ω
PM flux linkages ϕ_{pm}	2.08 Wb
L_d, L_q, M_d, M_q	24.0mH, 31.4mH, 14.6mH, 22.1mH

The system was subjected to different load conditions. The Permanent Magnet Synchronous Motor was operated for a reference speed of 35.6 rad/sec under the following conditions

CASE-I: At no-load condition

The simulation result with PI controller with no load torque is applied to the motor and its speed characteristics (fig. 3), torque characteristics (fig. 4) & current characteristics (fig. 5) as shown below.

CASEII: With change in load condition

Sudden change in load is applied to the motor from no load to 5 Nm load at 1.2 seconds. At this point waveform is distorted for few second or there is a fluctuation in speed for few seconds and at point 1.25 seconds motor again attained the normal speed and its speed characteristics (fig. 6), torque characteristics (fig. 7) current characteristics (fig. 8) are as shown below:

CASEII: With change in reference speed Condition

When initial reference speed is 35.6rad/sec and it changes to 45.6 rad/sec at $t = 1.2$ sec. initially motor gains its normal speed 35.6rad/sec and at 1.25 sec it is shifted to 45.6 rad/sec. That means PI-controller is sensitive to variation of the reference speed attention and its speed characteristics (fig. 9), torque characteristics (fig. 10) & current characteristics (fig. 11) are as shown below:

CONCLUSION

This paper investigate modelling of six phase PMSM supplied by two three phase inverters with a conventional three phase vector control. Because the conventional field oriented control does not take into account the magnetic coupling between the winding sets, the dynamic performance will decrease. However, a correct steady- state operating point will be achieved.

Mathematical and simulated modelling of six phase PMSM with six phase stator winding in synchronous reference frame is elaborated. Six phase current with 30 degrees phase shift can be easily seen in this paper.

Because the conventional field oriented control does not take into account the magnetic coupling between the winding sets, the dynamic performance will decrease. However, a correct steady- state operating point will be achieved.

REFERENCES

1. E. Levi, "Multiphase electrical machines for variable-speed applications," *IEEE Trans. Appl.* vol 55, pp. 1893-1909, May-2008.
2. E. Levi, R. Bojoi, F. Profumo, H.A. Toliyat and S. Williamson "Multiphase induction motor drive – a technology status review," *IET Electr. Power. Appl.* vol. 04, pp. 489-516, 2007.
3. J. C. Salmon and B. W. Williams, "A split-wound induction motor design to improve reliability of PWM inverter drives," *IEEE Trans. Indust. Appl.* vol. 26, no. 1, pp. 143-150, 1990
4. H. Zhang, A. Jouanne, S. Dau, K. Wallace, and F. Wang, "Multilevel inverter modulation schemes to eliminate common-mode voltages," *IEEE Trans. Appl.* vol. 36, no. 6, pp. 1645-1653, 2000.
5. S. Green, D. J. Atkinson, A. G. Jack, B. C. Mecrow and A. King, "Sensorless operation of a fault tolerant PM drive," *IEE Proc. Electr. Power. Appl.* vol 150, no. 2, pp. 117-125, 2003.
6. R. O. C. Lyra and T. A. Lipo, "Torque density improvement in a six-phase induction motor with third harmonic current injection," *IEEE Trans, indust. Appl. , Proc. Electr. Power. Appl.* vol 38, no. 5, pp. 1351-1360, 2002.
7. Duran M. J., Salas F., Arahal M. R., "Bifurcation Analysis of Five-Phase Induction Motor Drives With Third Harmonic Injection," // *Industrial Electronics, IEEE Transactions on*, 2008. – vol. 55, no. 5. – pp. 2006–2014
8. Singh G. K., Nam K., Lim S. K., "A Simple Indirect Field-Oriented Control Scheme for Multiphase Induction Machine," *Industrial Electronics, IEEE Transactions on*, 2005. – vol 52. – no. 4. – pp. 1177–1184.
9. Levi E. Editorial – Special Issue on Multi-Phase Motor Drives // *EPE Journal*, 2004. – vol. 14, No. 3. – pp. 4.
10. H. A. Toliyat, T. A. Lipo, and J. C. White, "Analysis of a concentrated winding induction machine for adjustable speed drive applications. Motor design and performance," *IEEE Transactions Energy Conversion*, vol. 6, pp. 684- 692, Dec 1991.
11. M. A. Fnaiech, F. Betin, G. Capolino, and F. Fnaiech, "Fuzzy logic and sliding-mode controls applied to six-phase induction machine with open phases," *IEEE Trans. Vehicu. Techn.*, vol. 56, no. 2, pp. 519-528, 2007. G. Eason, B. Noble, and I.N. Sneddon, "On certain integrals of Lipschitz-Hankel type involving products of Bessel functions," *Phil. Trans. Roy. Soc. London*, vol. A247, pp. 529-551, April 1955.
12. I. boldea, and S. A. Nasar, *Linear electric actuators and generators*. London U.K.: Cambridge University Press, 1997.
13. R. Kianinezhad, B. Nahid-Mobarakeh, L. Baghli, F. Betin, and G. Capolino, "Modelling and control of six-phase symmetrical Induction machine under fault condition with open phases," *IEEE Trans. Indust. Appl.* vol. 55, no. 5, pp. 1966-1977, 2008.
14. B. Kundrotas, S. Lisauskas, R. Rinkeviciene, "Model of Multiphase Induction Motor," // *IEE Proc. Electr. Power. Appl.* vol. 111, no. 5, pp. 1392-1215, 2011.
15. Karttunen, S. Kallio, P. Peltoniemi, P. Silventoinen, O. Pyrhonen "Dual three-phase permanent magnet synchronous machine supplied by two independent voltage source inverters," *Lappeenranta University Technology*, 2012.

BLOCK DIAGRAM OF SIX-PHASE PMSM DRIVE

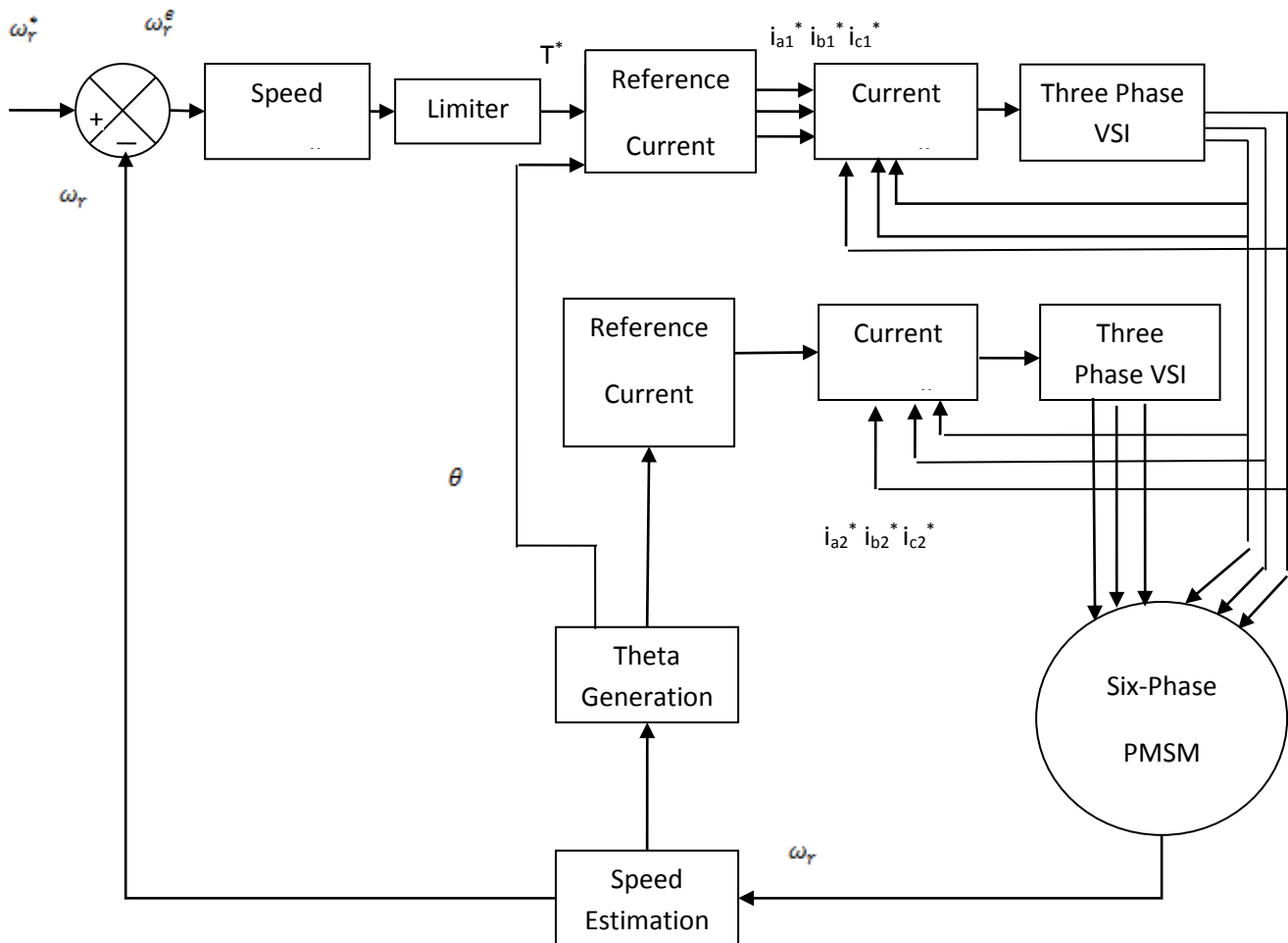

Fig. 2 Block Diagram of Six-Phase PMSM Drive System

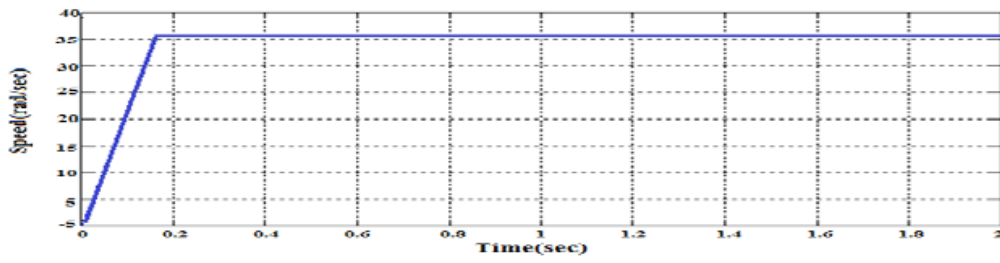

Fig. 3: Speed response at no-load

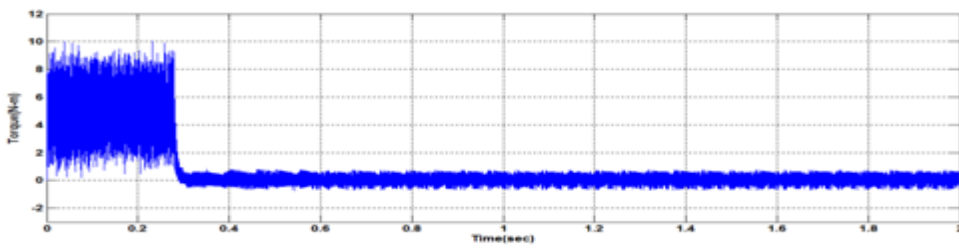

Fig. 4: Torque response at no-load

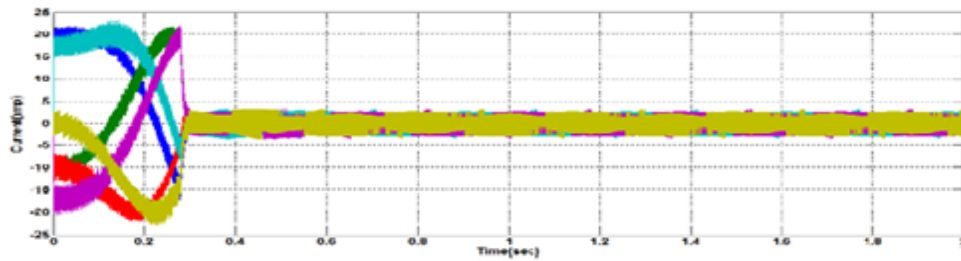

Fig. 5: Current response at no-load

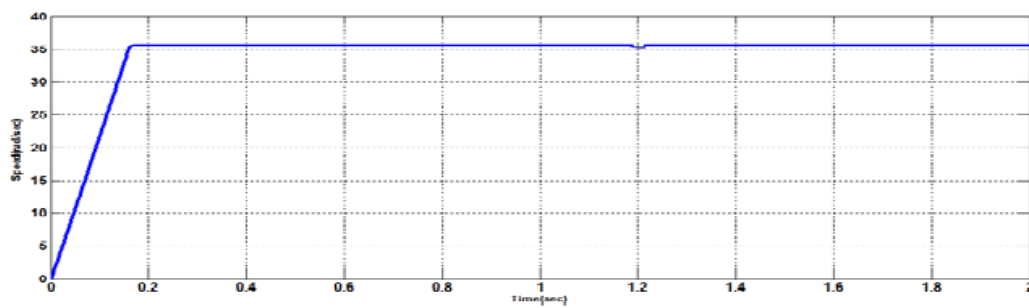

Fig. 6: Speed response at dynamic load

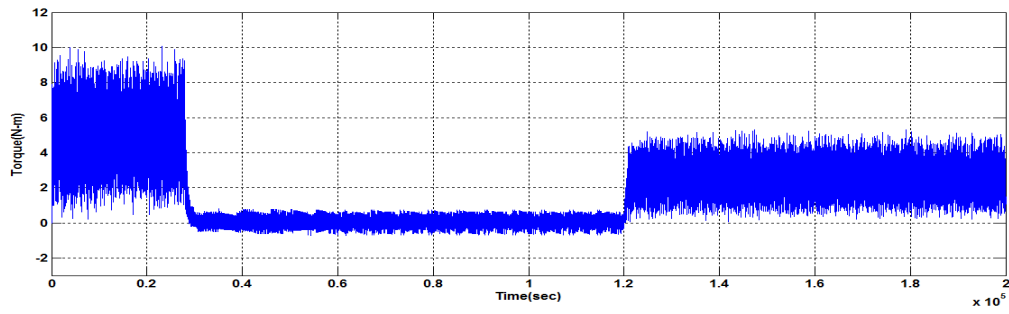

Fig. 7: Torque response at dynamic load

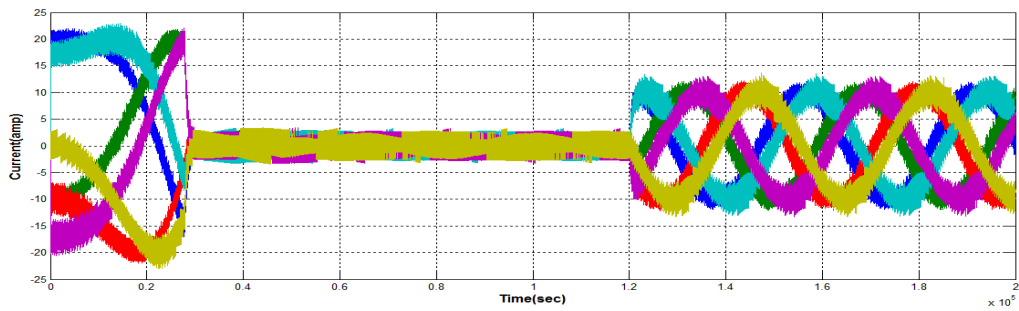

Fig. 8: Current response at dynamic load

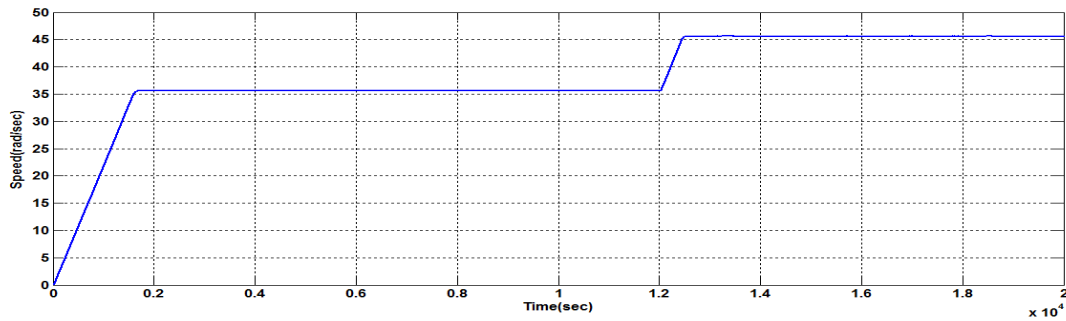

Fig. 9 Speed response at change in reference speed

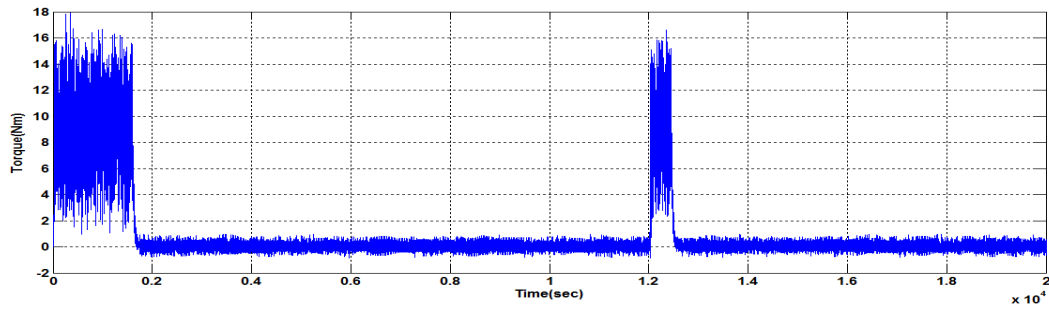

Fig. 10: Torque response at change in reference speed

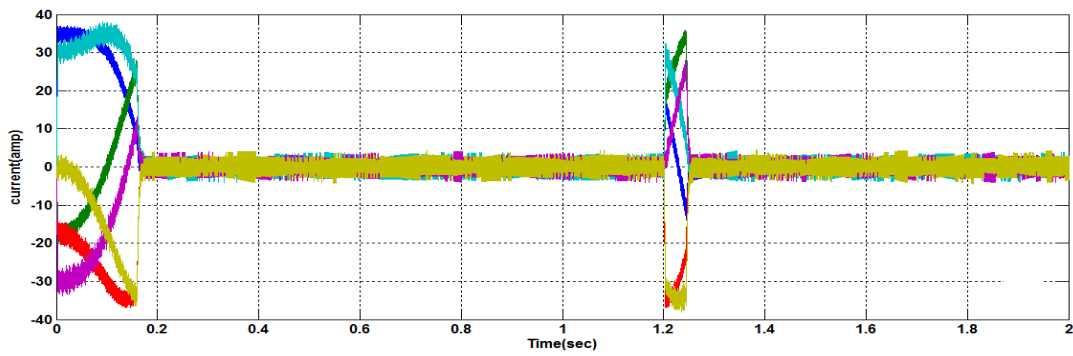

Fig. 11: Current response at change in reference speed